

800-5000 A Physical Data/Catalog Numbering System

Wall And Floor Flange

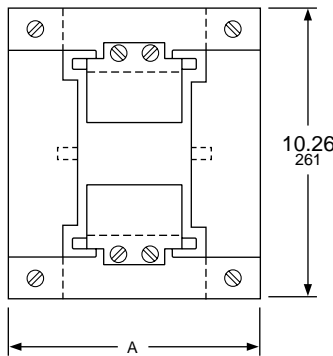

Ampere Rating		A		Catalog Number
Aluminum	Copper	IN	mm	
...	800	8.32	211	ACF-38-WF
...	1000	8.82	224	ACF-43-WF
...	1200	9.82	249	ACF-53-WF
...	1350	10.32	262	ACF-58-WF
...	...	10.82	275	ACF-63-WF
...	1600	11.22	285	ACF-67-WF
...	...	11.82	300	ACF-73-WF
...	2000	12.32	313	ACF-78-WF
...	...	13.32	338	ACF-88-WF
...	2500	17.20	437	ACF-13-WF
...	...	19.70	500	ACF-15-WF
...	3000	20.70	526	ACF-17-WF
...	...	23.20	589	ACF-19-WF
...	...	28.08	713	ACF-24-WF
...	4000	29.58	751	ACF-25-WF
...	...	30.08	764	ACF-26-WF

Required Wall And Floor Openings

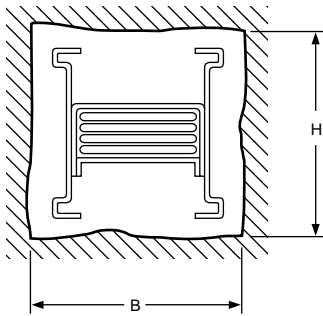

Ampere Rating		Str. Lnth.		Fl. End		Flatwise Elbow★						Edgewise Elbow★							
Aluminum	Copper	B	H	B	H	H	Wall Thickness						B	Wall Thickness					
							4	8	12	16	20	24		4	8	12	16	20	24
...	800	6	8	10	15	8	9	11	13	15	17	19	6	12	14	16	18	20	22
...	1000	6	8	10	15	8	10	12	14	16	18	20	6	12	14	16	18	20	22
...	1200	7	8	11	15	8	12	14	16	18	20	22	7	12	14	16	18	20	22
...	1350	8	8	12	15	8	12	14	16	18	20	22	8	12	14	16	18	20	22
...	...	8	8	13	15	8	13	15	17	19	21	23	8	12	14	16	18	20	22
...	1350	9	8	14	15	8	14	16	18	20	22	24	9	12	14	16	18	20	22
...	1600	10	8	17	21	8	15	17	19	21	23	25	10	12	14	16	18	20	22
...	2000	11	8	17	21	8	17	19	21	23	25	27	11	12	14	16	18	20	22
...	...	15	8	19	21	8	22	24	26	28	30	32	15	12	14	16	18	20	22
...	3000	17	8	23	21	8	26	28	30	32	34	36	17	12	14	16	18	20	22
...	...	18	8	23	21	8	27	29	31	33	35	37	18	12	14	16	18	20	22
...	2500	21	8	26	21	8	31	33	35	37	39	41	21	12	14	16	18	20	22
...	3000	26	8	32	21	8	37	39	41	43	45	47	26	12	14	16	18	20	22
...	...	27	8	32	21	8	40	42	44	46	48	50	27	12	14	16	18	20	22
...	4000	27	8	32	21	8	40	42	44	46	48	50	27	12	14	16	18	20	22
...	...	28	8	32	21	8	40	42	44	46	48	50	28	12	14	16	18	20	22

★Wall thickness is in inches. To convert to millimeters, multiply the thickness in inches by 25.4.

End Closure (Indoor Only)

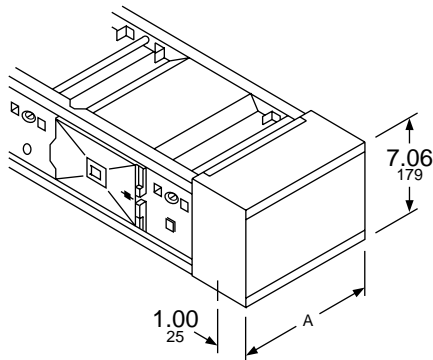

Ampere Rating		A		Catalog Number
Aluminum	Copper	IN	mm	
...	800	4.34	110	ACF-38-EC
...	1000	4.84	123	ACF-43-EC
...	1200	5.84	148	ACF-53-EC
...	1350	6.34	161	ACF-58-EC
...	...	6.84	174	ACF-63-EC
...	1600	7.24	184	ACF-67-EC
...	...	7.84	199	ACF-73-EC
...	2000	8.34	212	ACF-78-EC
...	...	9.34	237	ACF-88-EC
...	2500	13.22	336	ACF-13-EC
...	...	15.72	399	ACF-15-EC
...	3000	16.72	425	ACF-17-EC
...	...	19.22	488	ACF-19-EC
...	...	24.10	612	ACF-24-EC
...	4000	25.60	650	ACF-25-EC
...	...	26.10	663	ACF-26-EC

Dual Dimensions: INCHES
Millimeters



I-LINE® Busways (225–5000 Ampere)

General

I-LINE® Busway offers a complete line of compatible, sandwich type feeder and plug-in busway lengths and fittings. It allows maximum flexibility, ease of installation and electrical efficiency in the distribution of low voltage power for both commercial and industrial applications.

I-LINE busway has been used to supply power in thousands of installations throughout the world for more than three decades. Our broad range of I-LINE Busway products include: I-LINE Plug-In Style from 225 A–600 A with aluminum or copper conductors; I-LINE II Plug-In and Feeder styles from 800 A to 4000 A with aluminum conductors, and to 5000 A with copper conductors. I-LINE and I-LINE II busways are constructed in 3 pole and 4 pole full neutral configurations for system voltages to 600 volts and are rated to allow 100% of the current to flow continuously.

Busway installation is quick and easy. The compact, totally enclosed design is lightweight and easy to handle. Labor studies have shown a 75% savings in installation time is not uncommon when comparing I-LINE busway with cable and conduit installations. This significant reduction in installation time can result in total installed cost for busway being significantly lower than other distribution methods.

In addition, a wide variety of busway components and plug-in units are available from stock for fast delivery.

When you need busway, select the best...I-LINE busway. Our design and construction has been time-tested in many years of use throughout the world. No matter how you compare, I-LINE busway is your solid first choice!

Sandwich Construction

I-LINE feeder and plug-in busway both utilize sandwich type construction to provide superior voltage drop characteristics even at low power factors.

Steel housing sides and aluminum tops and bottoms have been carefully designed to reduce component weight and minimize the hysteresis and eddy current losses which are common in all steel housings.

Plug-in busway ratings which utilize two or three bus bars per phase have a phase paralleling feature at the joint assembly of each straight length. This helps equalize bus bar loading when plugs are mounted on one side only.

The plug-in housing has notches along the top rail for easy alignment and installation of plug-in units.

Within the same ampere rating, all I-LINE II Busway lengths and fittings are fully compatible between Feeder and Plug-In styles using standard universal tie channels (housing "splice plates") supplied with each component.

Totally Enclosed Housing

Ventilated busway depends on free air movement through a perforated housing to cool the bus bars. Unless mounted in its preferred position (maximum bus bar cooling), ventilated busway must be derated. Ventilated housing also permits dirt accumulation and limited protection of bus bars due to open ventilating slots in the housing.

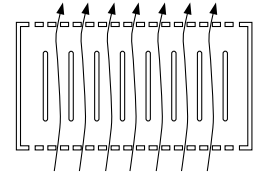

I-LINE busway has a modern "totally enclosed" housing design requiring no derating regardless of mounting position. Because the housing has no ventilating holes, the entry of dirt and possibility of accidental contact with bus bars is greatly reduced.

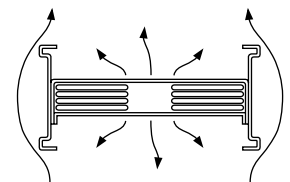

Compact Size

I-LINE II busway is compact. The small size means it may be used in locations where feeder circuits would not otherwise be possible. Efficient use of light weight raw materials is an additional factor in I-LINE busway's compact design.

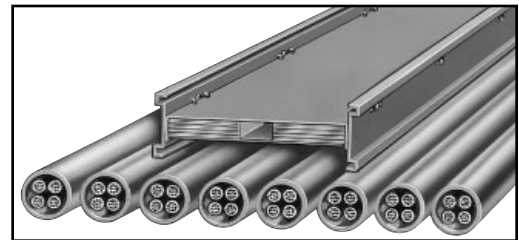

Finish

I-LINE busway housing appearance has been further enhanced by the addition of a multi-million dollar cationic electro-deposition paint system to our production facility. I-LINE busway users get a tough, durable uniform "E-Coat" epoxy paint finish making their busway installations functional and attractive for years to come.

Insulation

All bus bars are insulated using Class B rated (130°C vendor certified) materials to prolong insulation life. I-LINE busway insulation consists of two layers of heat-formed polyester film surrounding each bus bar. On plug-in busway lengths, all insulation is notched at the openings to allow plug-in unit mounting.

