

F-Frame

Table 12-188. 600V AC Maximum, 250V DC Maximum

NEMA Starter Size	Cont. Amps	Cam Setting	Motor Full Load Current Amps ①	MCP Trip Setting ②	MCP Catalog Number	Price U.S. \$
0	3	A	.69 – .91	9	HMCP003A0C	600.
		B	.92 – 1.0	12		
		C	1.1 – 1.2	15		
		D	1.3 – 1.5	18		
		E	1.6 – 1.7	21		
		F	1.8 – 1.9	24		
		G	2.0 – 2.2	27		
		H	2.3 – 2.5	30		
0	7	A	1.5 – 2.0	21	HMCP007C0C	600.
		B	2.1 – 2.5	28		
		C	2.6 – 3.1	35		
		D	3.2 – 3.6	42		
		E	3.7 – 3.9	49		
		F	4.3 – 4.7	56		
		G	4.8 – 5.2	63		
		H	5.3 – 5.7	70		
0	15	A	3.4 – 4.5	45	HMCP015E0C	600.
		B	4.6 – 5.6	60		
		C	5.7 – 6.8	75		
		D	6.9 – 7.9	90		
		E	8.0 – 9.1	105		
		F	9.2 – 10.3	120		
		G	10.4 – 11.4	135		
		H	11.5 – 12.6	150		
1	30	A	6.9 – 9.1	90	HMCP030H1C	600.
		B	9.2 – 11.4	120		
		C	11.5 – 13.7	150		
		D	13.8 – 16.0	180		
		E	16.1 – 18.3	210		
		F	18.4 – 20.6	240		
		G	20.7 – 22.9	270		
		H	23.0 – 25.2	300		
2	50	A	11.5 – 15.2	150	HMCP050K2C	760.
		B	15.3 – 19.1	200		
		C	19.2 – 22.9	250		
		D	23.0 – 26.8	300		
		E	26.9 – 30.6	350		
		F	30.7 – 34.5	400		
		G	34.6 – 38.3	450		
		H	38.4 – 42.1	500		

Table 12-188. 600V AC Maximum, 250V DC Maximum (Continued)

NEMA Starter Size	Cont. Amps	Cam Setting	Motor Full Load Current Amps ①	MCP Trip Setting ②	MCP Catalog Number	Price U.S. \$
2	70	A	16.1 – 21.4	210	HMCP070M2C	915.
		B	21.5 – 26.8	280		
		C	26.9 – 32.2	350		
		D	32.3 – 37.5	420		
		E	37.6 – 42.9	490		
		F	43.0 – 48.3	560		
		G	48.4 – 53.7	630		
		H	53.8 – 59.1	700		
3	100	A	23.0 – 30.6	300	HMCP100R3C	915.
		B	30.7 – 38.3	400		
		C	38.4 – 46.0	500		
		D	46.1 – 53.7	600		
		E	53.8 – 61.4	700		
		F	61.5 – 69.1	800		
		G	69.2 – 76.8	900		
		H	76.9 – 84.5	1000		
4	150	A	34.6 – 46.0	450	HMCP150T4C	1,320.
		B	46.1 – 57.5	600		
		C	57.6 – 69.1	750		
		D	69.2 – 80.6	900		
		E	80.7 – 92.2	1050		
		F	92.3 – 103.7	1200		
		G	103.8 – 115.2	1350		
		H	115.3 – 126.7	1500		
4	150	A	57.0 – 75.0	750	HMCP150U4C	1,320.
		B	76.0 – 95.0	1000		
		C	96.0 – 114.0	1250		
		D	115.0 – 130.7	1500		
		E	③	1750		
		F	③	2000		
		G	③	2250		
		H	③	2500		

- ① Motor FLA ranges are typical. The corresponding trip setting is at 13 times the minimum FLA value shown. Where a 13 times setting is required for an intermediate FLA value, alternate cam settings and/or MCP ratings should be used.
- ② For DC applications, actual trip levels are approximately 40% higher than values shown.
- ③ Settings above 130 amperes are for special applications. NEC Article 430-110(a) requires the ampere rating of the disconnecting means to be not less than 115% of the motor full load ampere rating.

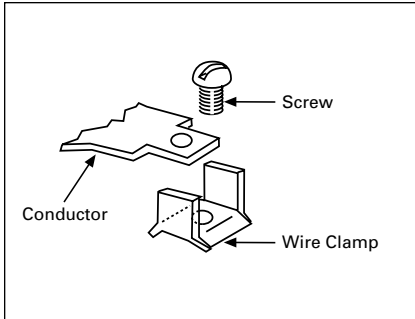
**Note:** Instruction Leaflet/FRED Number 29C401

**Note:** HMCP 3 – 100A come with line and load steel body terminals, 3T100FB. HMCP 150A come with line and load steel body terminals, 3T150FB.

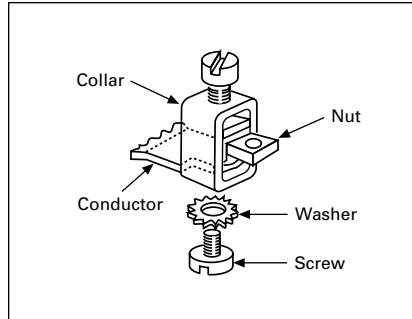
12

## F-Frame

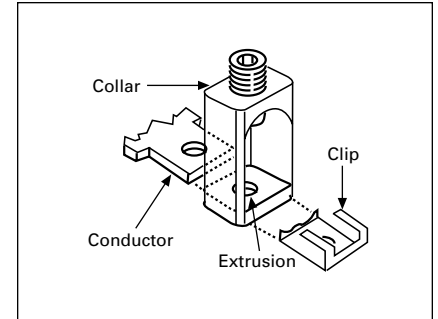
## Line and Load Terminals (Continued)



**Figure 12-1. 3T20FB**  
Assemble wire clamp to bottom of conductor as shown.

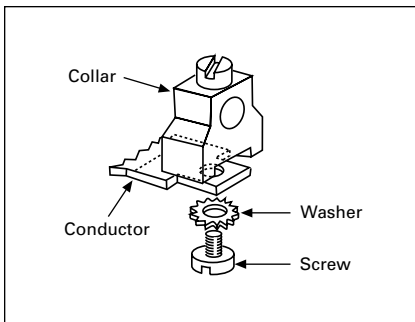


**Figure 12-2. 3T100FB, 3T150FB**  
Insert collar enclosing conductor as shown. Locate nut on top of conductor and tighten securely with screw and washer. Caution: Collar must surround conductor.

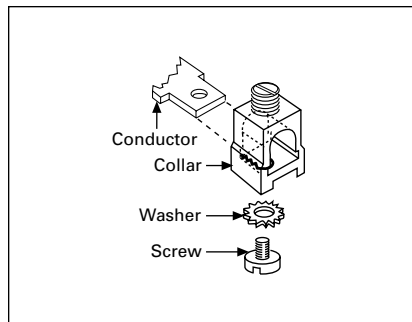


**Figure 12-3. 3TA225FD**  
Insert collar enclosing conductor and center on extrusion on collar. Install clip with legs on top of conductor and snap end around bottom of collar.

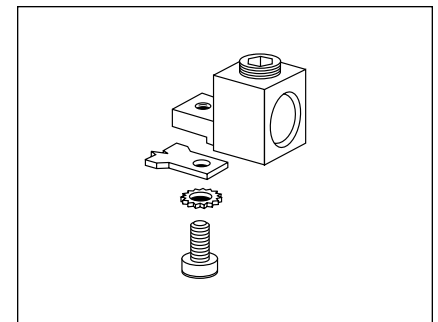
12



**Figure 12-4. 3TA50FB**  
Assemble collar on top of conductor as shown. Tighten securely with screw and washer.



**Figure 12-5. 3TA100FD**  
Collar slides onto conductor and is held in position by a screw and lockwasher.



**Figure 12-6. 3TA225FDK**  
Assemble collar on top of conductor as shown. Tighten securely with screw and washer. Terminal shield must be used with this collar.

**Contents**

Description	Page
<b>Motor Circuit Protectors</b>	
Product Description . . . . .	12-116
Product Selection . . . . .	12-117

**Motor Circuit Breakers***Motor Circuit Protectors***Product Description**

Designated as the Cutler-Hammer Types GMCP, HMCPE and HMCP, the instantaneous-only Motor Circuit Protector (MCP) is available in ratings from 3A to 1200A for motor starter sizes 0 through 8. The MCP is designed to comply with the applicable requirements of Underwriters Laboratories Standard UL489, Canadian Standards Association Standard C22.2 No. 5.1, and International Electrotechnical Commission Recommendations IEC 157-1.

An innovative design of internal components allows higher MCP-starter combination interrupting ratings. The MCP is marked to permit proper electrical application within the assigned equipment ratings.

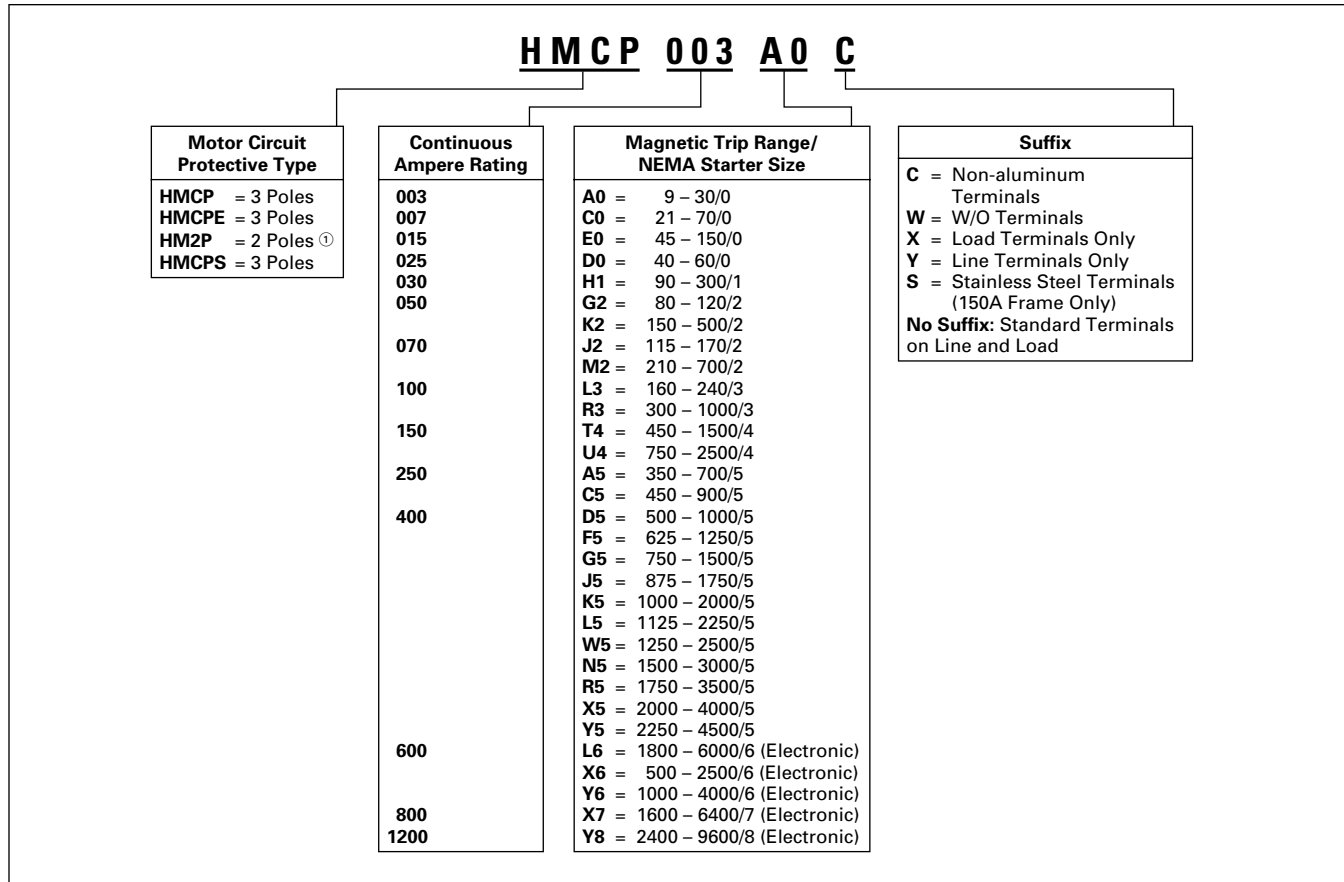
The MCP is a recognized component (UL File E7819) and complies with the applicable requirements of Underwriters Laboratories Standard UL489. It is also designed to comply with the applicable requirements of Canadian Standards Association Standard C22.2 No. 5.1, International Electrotechnical Commission Recommendations IEC 157-1, and nameplates bear the CE marking.

**Note:** Interrupting ratings are dependent on starter it is used with. See FRED 278.

**Product Selection**

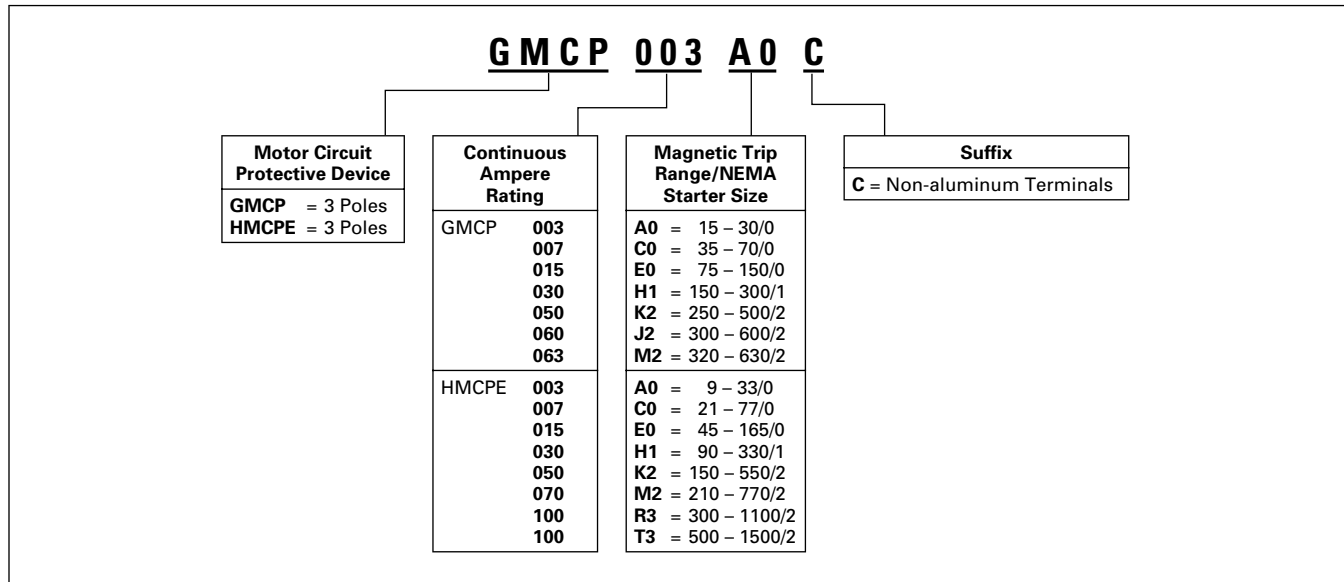
This information is presented only as an aid to understanding Catalog Numbers. It is not to be used to build Catalog Numbers for circuit breakers or trip units.

**Table 12-181. Motor Circuit Protector Catalog Numbering System**



<sup>①</sup> On J- and K-Frame HMCPs only.

**Table 12-182. Motor Circuit Protector Catalog Numbering System**



Alarm Switch

Table 12-293. G-Frame Alarm Switch (RH only) ①

Electrical Rating			Contact Arrangement	Catalog Number ②③④	Price U.S. \$	Factory Suffix	Adder U.S. \$
Volts	Frequency	Amperes					
<b>Alarm Switch</b>							
240	50/60 Hz	6	1 Make/1 Break	1288C75G03	200.	B3	200.
<b>Alarm Switch Auxiliary Switches Combination</b>							
240	50/60 Hz	6	1 Make/1 Break and 1a/1b	1288C76G09	400.	B13	400.

- ① F-Frame circuit breakers are factory sealed. Underwriters Laboratories, requires that internal accessories be installed at the factory. Internal accessories are UL listed for factory installation under E7819. Where local codes and standards permit and UL listing is not required, internal accessories can be field installed. Accessory installation should be done before the circuit breaker is mounted and connected.
  - ② Includes 24-inch (609.6 mm) external pigtail leads, 18 AWG (16-.010).
  - ③ A maximum of two internal accessories may be mounted in a 3-pole circuit breaker.
  - ④ Suitable for mounting in right pole only of 2- or 3-pole breaker.
- Note:** Instruction Leaflet/FRED Number 15552. See Page 12-161.

Table 12-294. E125 Alarm Switch

Electrical Ratings			Contact Arrangement	Catalog Number	Price U.S. \$
Volts	Frequency Hz	Amperes			
600	50/60	6	1M – 1B	ALM1M1BEPK	200.
125	DC	0.5	2M – 2B	ALM2M2BEPK	400.
250	DC	0.25			

Table 12-295. F-Frame Alarm Switch ⑤

Number of Contacts (Make and Break)	Mounting Location (Pole)	Factory Mounted								Field Mounted					
		Connection Type and Location										Field Installation Kits ⑥			
		18-Inch (457.2 mm) Pigtail Leads								Terminal Block					
		Same Side				Opposite Side				Same Side					
Suffix Number	Adder U.S. \$	Suffix Number	Adder U.S. \$	Suffix Number	Adder U.S. \$	Suffix Number	Adder U.S. \$	Suffix Number	Adder U.S. \$	Suffix Number	Adder U.S. \$	Catalog Number	Price U.S. \$	Catalog Number	Price U.S. \$
1	Left ⑦	B01	200.	B02	200.	B03	200.	B04	200.	A1L1LPK	200.	A1L1LTK	200.		
	Right	B05	200.	B06	200.	B07	200.	B08	200.	A1L1RPK	200.	A1L1RTK	200.		
2	Left ⑦	B09	400.	B10	400.	—	—	B11	400.	A2L1LPK	400.	A2L1LTK	400.		
	Right	B12	400.	B13	400.	—	—	B14	400.	A2L1RPK	400.	A2L1RTK	400.		
1 (Make Only)	Single-Pole	B15 ⑧		—		—		—		—		—			

- ⑤ F-Frame circuit breakers are factory sealed. Underwriters Laboratories, requires that internal accessories be installed at the factory. Internal accessories are UL listed for factory installation under E7819. Where local codes and standards permit and UL listing is not required, internal accessories can be field installed. Accessory installation should be done before the circuit breaker is mounted and connected.
  - ⑥ Not listed with Underwriters Laboratories, for field installation.
  - ⑦ Standard pigtail lead exit location.
  - ⑧ Standard mounting location.
  - ⑨ Factory installation only. Leads exit load end of circuit breaker.
- Note:** Instruction Leaflet/FRED Number 29C180

Table 12-296. J250 Alarm Switch

Electrical Ratings			Contact Arrangement	Catalog Number	Price U.S. \$
Volts	Frequency Hz	Amperes			
600	50/60	6	1M – 1B	ALM1M1BEPK	200.
125	DC	0.5	2M – 2B	ALM2M2BEPK	400.
250	DC	0.25			

Table 12-297. J-Frame Alarm Switch

Number of Contacts (Make and Break)	Mounting Location (Pole)	Factory Mounted								Field Mounted					
		Connection Type and Location										Field Installation Kits ⑩			
		18-Inch (457.2 mm) Pigtail Leads								Terminal Block					
		Same Side				Rear ⑪				Opposite Side					
Suffix Number	Adder U.S. \$	Suffix Number	Adder U.S. \$	Suffix Number	Adder U.S. \$	Suffix Number	Adder U.S. \$	Suffix Number	Adder U.S. \$	Suffix Number	Adder U.S. \$	Catalog Number	Price U.S. \$	Catalog Number	Price U.S. \$
1	Left ⑫	B01	200.	B02	200.	B03	200.	B04	200.	A1L2LPK	200.	A1L2LTK	200.		
	Right	B05	200.	B06	200.	B07	200.	B08	200.	A1L2RPK	200.	A1L2RTK ⑬	200.		

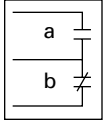
- ⑩ Listed with Underwriters Laboratories, for field installation on interchangeable trip unit breakers under E64983.
  - ⑪ Standard mounting location.
  - ⑫ Standard mounting location — leads exit rear of breaker.
- Note:** Instruction Leaflet/FRED Number 29C181

Discount Symbol ..... CB-2



## Auxiliary Switch

## Auxiliary Switch



The Auxiliary Switch provides circuit breaker contact status information by monitoring the position of the molded cross bar which contains the moving contact arms. The auxiliary switch is used for remote indication and interlock system verification, and consists of one or two SPDT switches housed in a plug-in module. Each SPDT switch has one "a" and one "b" contact. When the circuit breaker contacts are open, the "a" contact is open and the "b" contact is closed.

Table 12-302. F-Frame Electrical Rating Data <sup>①②</sup>

Maximum Voltage	Frequency	Maximum Current Amperes	Dielectric Withstand Voltage
125 <sup>③</sup>	50/60 Hz	1	2500
600	50/60 Hz	6	
125	DC	0.50 <sup>④</sup>	
250	DC	0.25 <sup>④</sup>	

- ① Endurance: 6000 electrical operations plus 4000 mechanical operations.  
 ② Pigtail wire size: 18 AWG (0.82 mm<sup>2</sup>).  
 ③ For use in electronic circuit of 100 micro-amperes and 15V DC minimum.  
 ④ Non-inductive load.

Table 12-303. J-Frame Electrical Rating Data <sup>⑤⑥</sup>

Maximum Voltage	Frequency	Maximum Current Amperes	Dielectric Withstand Voltage
600	50/60 Hz	6	2500
125	DC	0.50 <sup>⑦</sup>	
250	DC	0.25 <sup>⑦</sup>	

- ⑤ Endurance: 6000 electrical operations plus 4000 mechanical operations.  
 ⑥ Pigtail wire size: 18 AWG (0.82 mm<sup>2</sup>).  
 ⑦ Non-inductive load.

Table 12-304. K-Frame Electrical Rating Data <sup>⑧⑨</sup>

Maximum Voltage	Frequency	Maximum Current Amperes	Dielectric Withstand Voltage
600	50/60 Hz	6	2500
125	DC	0.50 <sup>⑩</sup>	
250	DC	0.25 <sup>⑩</sup>	

- ⑧ Endurance: 5000 electrical operations plus 1000 mechanical operations.  
 ⑨ Pigtail wire size: 18 AWG (0.82 mm<sup>2</sup>).  
 ⑩ Non-inductive load.

Table 12-308. G-Frame Auxiliary Switch (RH only)

Electrical Ratings			Contact Arrangement	Catalog Number <sup>⑪⑫</sup>	Price U.S. \$	Factory Suffix	Adder U.S. \$
Volts	Frequency	Amperes					
240	50/60 Hz	6	1a/1b	1288C74G03	200.	A3	200.
240	50/60 Hz	6	2a/2b	1288C73G03	400.	A6	400.

⑪ Includes 24-inch external pigtail leads, 18 AWG (16-.010).

⑫ A maximum of two internal accessories may be mounted in a 3-pole circuit breaker. Suitable for mounting in right pole only of 2- or 3-pole breaker.

Note: Instruction Leaflet/FRED Number 15551

Table 12-309. E125 Auxiliary Switch

Electrical Ratings			Contact Arrangement	Catalog Number	Price U.S. \$
Volts	Frequency Hz	Amperes			
600	50/60	6	1A – 1B	AUX1A1BPK	200.
125	DC	0.5	2A – 2B	AUX2A2BPK	400.
250	DC	0.25			

Note: Instruction Leaflet/FRED Number 29C153

Table 12-305. L- and M-Frames Electrical Rating Data <sup>⑪</sup>

Maximum Voltage	Frequency	Maximum Current Amperes	Dielectric Withstand Voltage
600	50/60 Hz	6	2500
125	DC	0.50 <sup>⑫</sup>	
250	DC	0.25 <sup>⑫</sup>	

⑪ Pigtail wire size: 18 AWG (0.82 mm<sup>2</sup>).

⑫ Non-inductive load.

Table 12-306. N-Frame Electrical Rating Data <sup>⑬⑭</sup>

Maximum Voltage	Frequency	Maximum Current Amperes	Dielectric Withstand Voltage
600	50/60 Hz	6	2500
125	DC	0.50 <sup>⑮</sup>	
250	DC	0.25 <sup>⑮</sup>	

⑬ Endurance: 3000 electrical operations plus 1000 mechanical operations.

⑭ Pigtail wire size: 18 AWG (0.82 mm<sup>2</sup>).

⑮ Non-inductive load.

Table 12-307. R-Frame Electrical Rating Data <sup>⑯⑰</sup>

Maximum Voltage	Frequency	Maximum Current Amperes
600	50/60 Hz	6
125	DC	0.50 <sup>⑱</sup>
250	DC	0.25 <sup>⑱</sup>

⑯ Endurance: 500 electrical operations plus 2500 mechanical operations.

⑰ Pigtail wire size: 18 AWG (0.82 mm<sup>2</sup>). Leads are red, black and blue.

⑱ Non-inductive load.

## Auxiliary Switch

**Table 12-310. F-Frame Auxiliary Switch**

Number of Contacts a and b	Mounting Location (Pole)	Factory Mounted								Field Mounted			
		Connection Type and Location								Field Installation Kits <sup>②</sup>			
		18-Inch (457.2 mm) Pigtail Leads								Terminal Block			
		Same Side				Rear <sup>③</sup>				Opposite Side			
Suffix Number	Adder U.S. \$	Suffix Number	Adder U.S. \$	Suffix Number	Adder U.S. \$	Suffix Number	Adder U.S. \$	Suffix Number	Adder U.S. \$	Catalog Number	Price U.S. \$	Catalog Number	Price U.S. \$
1	Left <sup>①</sup>	A01	200.	A02	200.	A03	200.	A04	200.	A1X1PK	200.	A1X1LTK	200.
	Right or Neutral	A15 <sup>④</sup>	200.	A16 <sup>④</sup>	200.	A17 <sup>④</sup>	200.	—	200.	E1X1PK	201.	—	—
		A05	200.	A06	200.	A07	200.	A08	200.	A1X1PK	200.	A1X1RTK <sup>⑤</sup>	200.
2	Left <sup>①</sup>	A09	400.	A10	400.	—	—	A11	400.	A2X1LPK	400.	A2X1LTK	400.
	Right or Neutral	A21 <sup>④</sup>	400.	A22 <sup>④</sup>	400.	—	—	—	400.	E2X1LPK	400.	—	—
		A12	400.	A13	400.	—	—	A14	400.	A2X1RPK	400.	A2X1RTK <sup>⑤</sup>	400.
		A23 <sup>④</sup>	400.	A24 <sup>④</sup>	400.	—	—	—	400.	E2X1RPK	400.	—	—

<sup>①</sup> Pigtail wire size: 18 AWG (0.82 mm<sup>2</sup>).

<sup>②</sup> Not listed with Underwriters Laboratories, for field installation.

<sup>③</sup> Standard pigtail lead exit location.

<sup>④</sup> 125V (Max.), 50/60 Hz switch for use in electronic circuit of 100 micro-amp and 15V DC minimum.

<sup>⑤</sup> Not for use on 4-pole circuit breakers.

**Note:** Instruction Leaflet/FRED Number 29C120

**Table 12-311. J250 Auxiliary Switch**

Electrical Ratings			Contact Arrangement	Catalog Number	Price U.S. \$
Volts	Frequency Hz	Amperes			
600	50/60	6	1A – 1B	AUX1A1BPK	200.
125	DC	0.5	2A – 2B	AUX2A2BPK	400.
250	DC	0.25			

**Note:** Instruction Leaflet/FRED Number 29C153

**Table 12-312. J-Frame Auxiliary Switch**

Number of Sets of Contacts (1a and 1b)	Mounting Location (Pole)	Factory Mounted								Field Mounted			
		Connection Type and Location								Field Installation Kits <sup>⑥</sup>			
		18-Inch (457.2 mm) Pigtail Leads								Terminal Block			
		Same Side				Rear <sup>⑦</sup>				Opposite Side			
Suffix Number	Adder U.S. \$	Suffix Number	Adder U.S. \$	Suffix Number	Adder U.S. \$	Suffix Number	Adder U.S. \$	Suffix Number	Adder U.S. \$	Catalog Number	Price U.S. \$	Catalog Number	Price U.S. \$
1	Left	A01	200.	A02	200.	A03	200.	A04	200.	A1X2PK	200.	A1X2LTK	200.
	Right <sup>⑦</sup>	A05	200.	A06	200.	A07	200.	A08	200.	A1X2PK	200.	A1X2RTK <sup>⑧</sup>	200.
2	Left	A09	400.	A10	400.	—	400.	A11	400.	A2X2PK	400.	A2X2LTK	400.
	Right <sup>⑦</sup>	A12	400.	A13	400.	—	400.	A14	400.	A2X2PK	400.	A2X2RTK <sup>⑧</sup>	400.

<sup>⑥</sup> Listed with Underwriters Laboratories for field installation or interchangeable trip unit breakers under E64983.

<sup>⑦</sup> Standard mounting location — leads exit rear of breaker.

<sup>⑧</sup> Not for use on 4-pole circuit breakers.

**Note:** Instruction Leaflet/FRED Number 29C121

**Table 12-313. K-Frame Auxiliary Switch**

Number of Sets of Contacts (1M and 1B)	Mounting Location (Pole)	Factory Mounted								Field Mounted			
		Connection Type and Location								Field Installation Kits <sup>⑨</sup>			
		18-Inch (457.2 mm) Pigtail Leads								Terminal Block			
		Same Side				Rear <sup>⑩</sup>				Opposite Side			
Suffix Number	Adder U.S. \$	Suffix Number	Adder U.S. \$	Suffix Number	Adder U.S. \$	Suffix Number	Adder U.S. \$	Suffix Number	Adder U.S. \$	Catalog Number	Price U.S. \$	Catalog Number	Price U.S. \$
1	Left	A01	200.	A02	200.	A03	200.	A04	200.	A1X3PK	200.	A1X3LTK	200.
	Right <sup>⑩</sup>	A05	200.	A06	200.	A07	200.	A08	200.	A1X3PK	200.	A1X3RTK <sup>⑪</sup>	200.
2	Left	A09	400.	A10	400.	—	400.	A11	400.	A2X3PK	400.	A2X3LTK	400.
	Right <sup>⑩</sup>	A12	400.	A13	400.	—	400.	A14	400.	A2X3PK	400.	A2X3RTK <sup>⑪</sup>	400.
3	Left	A18	600.	—	—	—	—	A15	600.	A3X3LPK	610.	A3X3LTK	600.
	Right	A17	600.	—	—	—	—	A16	600.	A3X3RPK	610.	A3X3RTK <sup>⑪</sup>	600.

<sup>⑨</sup> Listed with Underwriters Laboratories for field installation under E64983.

<sup>⑩</sup> Standard mounting location — leads exit rear of breaker.

<sup>⑪</sup> Not for use on 4-pole circuit breaker.

**Note:** Instruction Leaflet/FRED Number 29C122

Discount Symbol ..... CB-2